

RP312

Fieldbus H1 Network Signal Repeater and Conditioner.

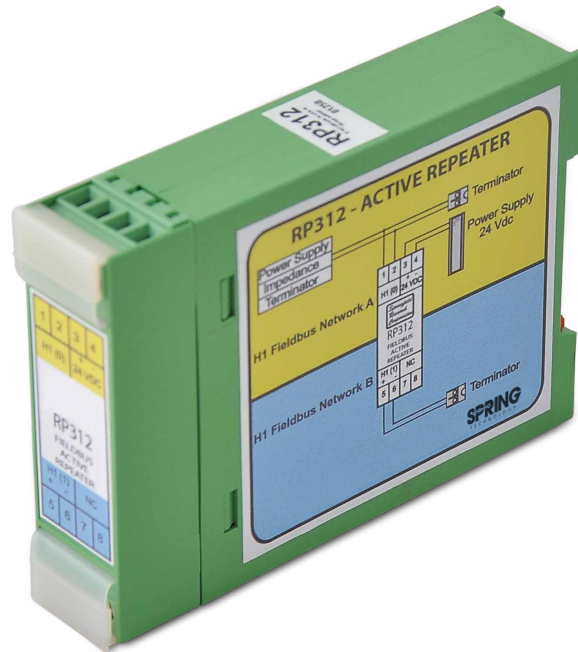

Description

The Fieldbus repeater RP312 is mainly designed to extend the network length for industrial network, can be used on either Foundation Fieldbus or Profibus PA.

Its unique ASIC based signal analyzer is geared to manage Fieldbus traffic between 2 bi-directional ports for Network 0 and 1, the galvanic isolation will allow communication with different electrical environments, or areas with different grounding circuits, for instance network leading to other buildings or inside areas restricted by EMI emission.

The RP312 is adequate for expanding a segment beyond the limit of 1900m, and also to add new instruments into a pre-existing Fieldbus segment without any changes into the original conditions of the network. The RP312 has also a Fieldbus power supply with integral terminator built in the network 1 port, eliminating the need for external components for the extra run.

Features

- Compatible with IEC 61158-2, 31.25 kb/s, FOUNDATION Fieldbus H1, and Profibus PA
- Allow extension of the network length beyond the 1900m Fieldbus specification.
- Built-in Fieldbus power conditioner for network 1, allowing up to 125mA @18Vdc.
- Built-in terminator on network 1 port.
- Low leakage current ($< 1 \mu\text{Adc}$) will not interfere with network power.
- Galvanic isolation between networks will block noise-jitter propagation.
- Small size and light weight enclosure for DIN mounting rail.

The purpose of this document is assist with the setup, installation, operation and maintenance of the RP312 as well as providing technical specifications and basic data, for further information about this product can be found at www.springres.com

Table of Contents

1 - General information	02
2 - Mounting & Electrical	03
3 - Electric Wiring	03
4 - Functional Specifications	04
5 - Performance Specification	04
6 - Physical Specification	05
7 - Hardware Configuration	05
7.1 - Power Supply Input	05
7.2 - Fieldbus Network	07
8 - Software Configuration	08
9 - Mechanical Dimensions	08

1 General Information

Fieldbus protocol is specifically oriented for process control application. Each communication segment can cover up to 1900 meters, can address 32 devices and the network can optionally provide DC voltage to power the instruments in the field.

Whenever field devices drain current from a DC line it can generate electrical noise (referred as voltage ripple), the more instruments and longer the line the worse is the problem, sometimes resulting into unacceptable levels disturbing communication and even causing instrument failure.

The RP312 is designed to allow 32 instruments to be linked via shorter lines with less instruments on each line, resulting into substantial reduction in noise levels and minimizing ground loop hazards. Its built in Fieldbus power supply/conditioner will save external components on network 1 port.

The RP312 consists of 3 port isolation architecture, the Power Supply input plus the Network 0 and 1 bidirectional ports galvanically isolated from each other. This feature will allow total flexibility for connecting different ground systems and distribution of power supplies in accordance to particular grounding rules. Whatever noise or discharge appears in a certain port will not be transmitted to the pairing port, therefore will keep the noise limited to the originating section of the segment.

The electronic functionality of this system will read the Manchester signal from a Network, evaluate compatibility with Fieldbus standard, case correct it will be retransmitted to the other Network recovering voltage levels and eliminating noise, ripples and jitter errors. The RP312 has an ultra-fast response ranging from 1 to 2 bit time this will ensure there will be no traffic collisions on the Networks being connected. The RP312 will add minimum time delay between retransmissions, keeping its presence transparent in the segment

2 Mounting & Electrical

The RP312 is mechanically designed to mount straight into a DIN rail track, or can be bolted directly into wall or panel. We recommend the use within an enclosed electrical panel with adequate ventilation. There are no limits for stacking repeaters alongside each other, but heat generating devices must be kept away from the RP312, we suggest at least 50mm distance from any electronic heat sources.

3 Electric Wiring

Figure 3.1 and the table below describe the electrical designators of the RP312 terminals.

Pin #	Designator
1	Fieldbus I/O - Network 0
2	Fieldbus I/O - Network 0
3	24 VDC - Power Supply (+)
4	24 VDC - Power Supply (-)
5	Fieldbus I/O - Network 1
6	Fieldbus I/O - Network 1
7	Do Not Use
8	Do Not Use

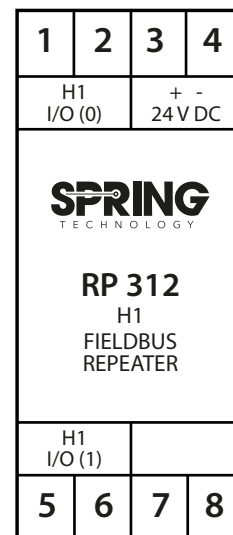
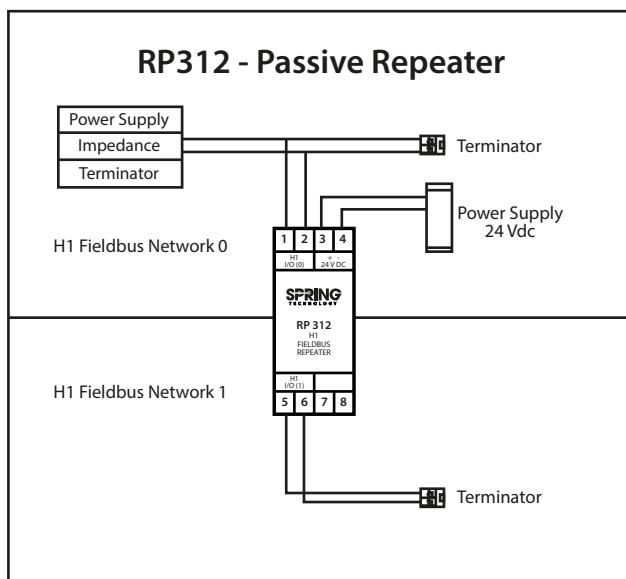

4 Functional Specifications

- Power Supply Input: 24Vdc, max icc = 150mA.
- Nom. Power Dissipation: 0.72W @24Vdc
- Operating Temp.: -20 to 60C
- Storage Temp.: -20 to 75C
- Humidity: 10 to 90%

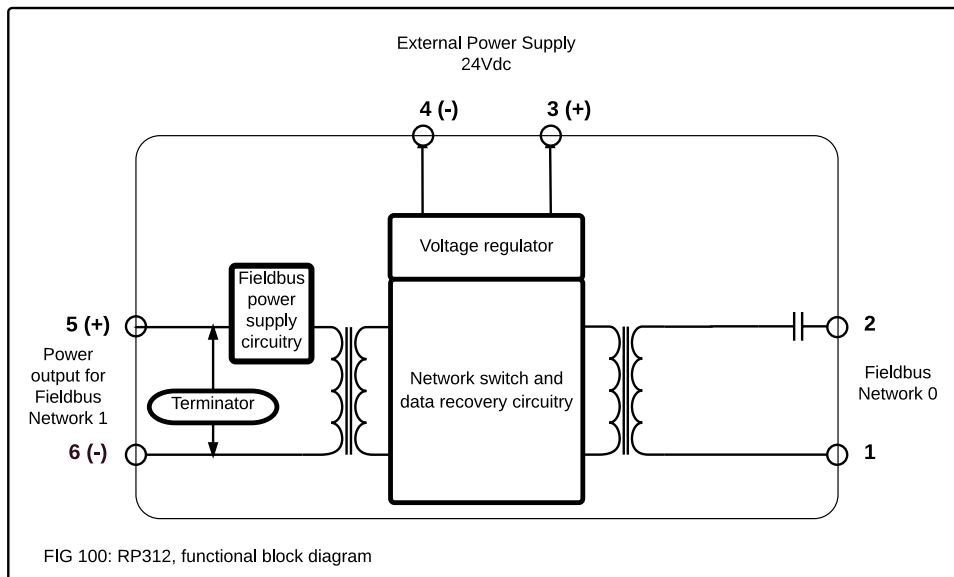

Fig. 4.1 – RP312, Functional Block Diagram

5 Performance Specifications

Bidirectional Network 0:

Protocol:	IEC-61158-2 31.25kpbs
Modulation:	Manchester II, 31.25kps, jitter recovery +/-10%.
Transmit Levels:	0.75Vpp to 1Vpp @ 50 Ohm network impedance.
Receiver Levels:	0.15Vpp to 1.5Vpp, noise rejection 0.075Vpp
Signal recognition:	1 valid preamble for Fieldbus H1.

Bidirectional Network 1:

Protocol:	IEC-61158-2 31.25kpbs
Modulation:	Manchester II, 31.25kps, jitter recovery +/-10%.
Transmit Levels:	0.75Vpp to 1Vpp @ 50 Ohm network impedance.
Receiver Levels:	0.15Vpp to 1.5Vpp, noise rejection 0.075Vpp
Signal recognition:	1 valid preamble for Fiedlbus H1.
Fieldbus Power:	125mA @ 18Vdc, 22Vdc at no load.

Isolation between ports:

Min. 250Vac, factory tested at 750Vdc

6 Physical Specifications

Electrical Connection:	Fieldbus cable up to 1900m. Ground shielding suggested.
-------------------------------	--

Mounting:	Snap mount to DIN-rail no special requirement, or bolted into panel assembly via 4mm screws.
------------------	---

7 Hardware Configuration

The RP312 is composed of 3 sections, the voltage regulator input, the Fieldbus network 0 bidirectional port plus the Fieldbus network 1 bidirectional port, all these sections are galvanically isolated from each other enabling full operational flexibility. These sections are designed to satisfy the respective protocols and provide transparent Fieldbus communication and also keeping the 2 networks electrically isolated to prevent damaging ground faults.

Figure 4.1 page 4 show these sections and their respective connecting terminals and configurations.

7.1 Power Supply Input

The RP312 power supply input can be connected to any industrial 24 Vdc power source with ripple or tolerance +/- 10%, such supply must have low EMI and protected against electrical discharges. The nominal input current is around 30mA, the RP312 will cause minimum current ripple through the supply line, therefore causing with low emission.

Figures 7.1.1, 7.1.2 and 7.1.3 of pages 6 and 7 will show connection practices for the possible network topologies, important to know the RP312 can be powered from any power source, for illustration purposes we connected to the same power supply equipment feeding the nearby network.

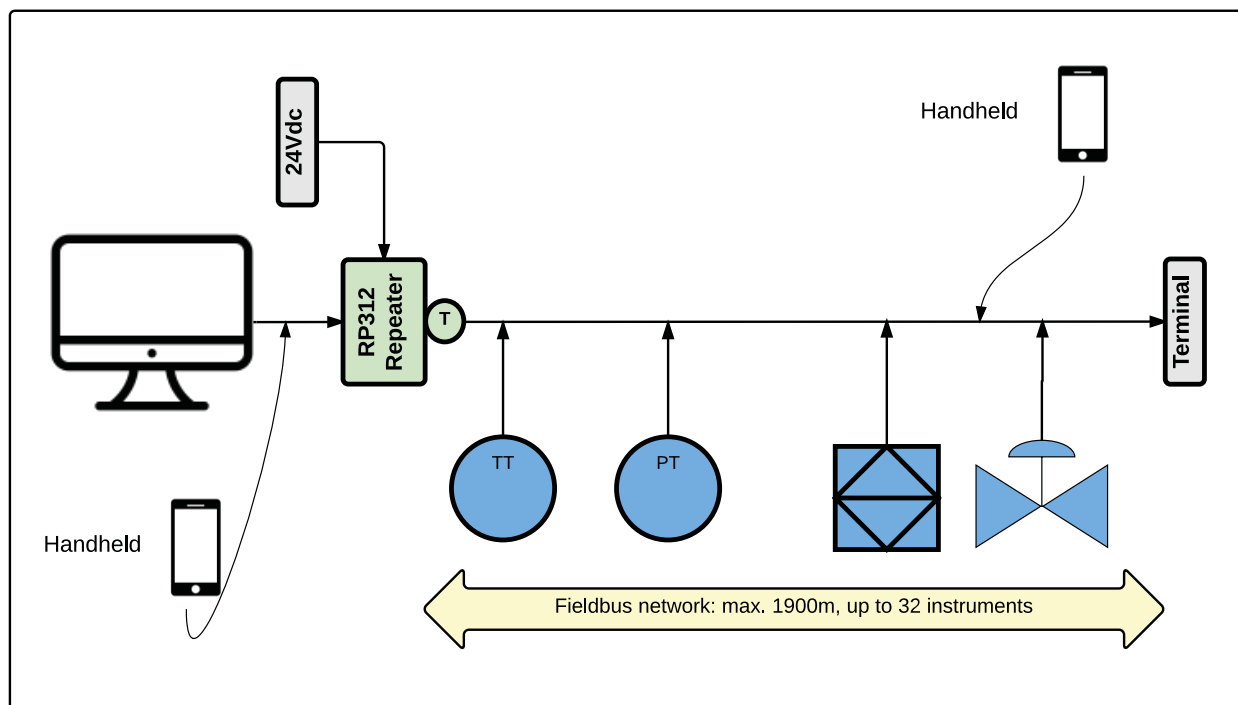

Figure 7.1.1 RP312 in a Single Multidrop Topology

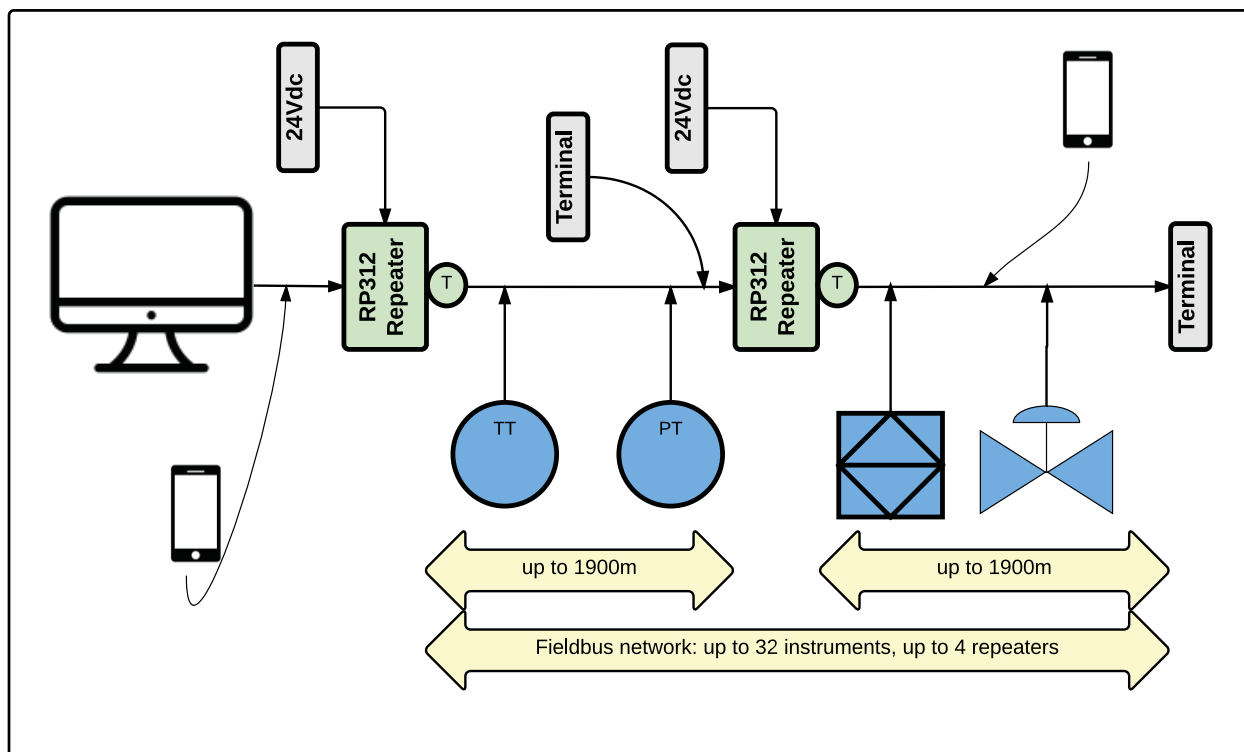

Figure 7.1.2 RP312 in a Daisy Chain Topology

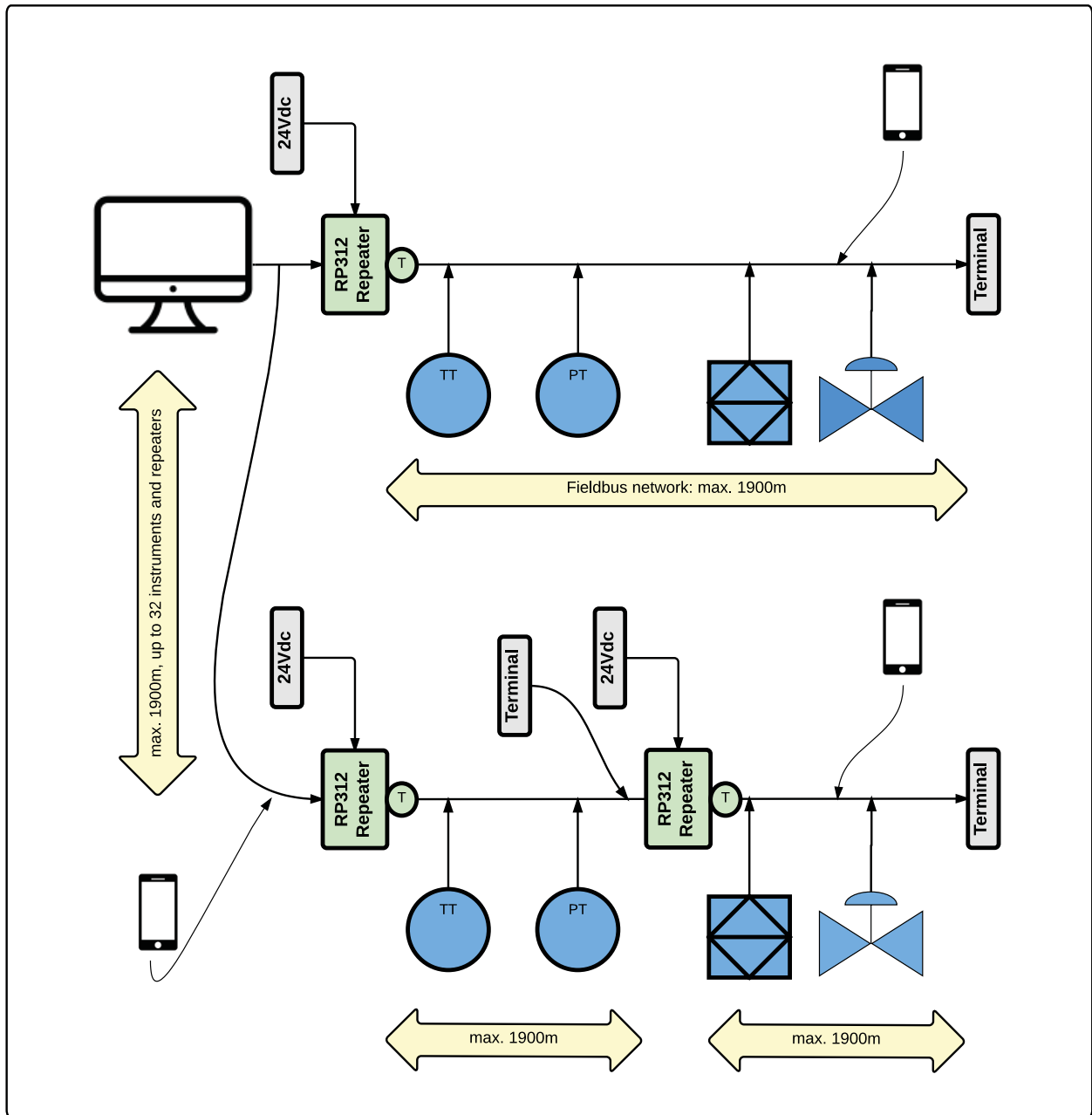

Figure 7.1.3 RP302 in a Tree Combined With Daisy Chain Topology

7.2 Fieldbus Network 0 and Network 1 Bidirectional Inputs

The RP312 Fieldbus inputs will follow the protocol standard IEC-61158-2, the main function is to read a Fieldbus signal from one network, recondition such signal in accordance to Fieldbus specification and retransmit to the pairing network. Retransmission is done immediately after the RP312 recognize a Fieldbus preamble from originating network, therefore the repeater will not interfere with the segment communication timing.

The classical application of the RP312 is shown on Figure 7.1.1 page 5 with one repeater in a single multi drop topology, the main advantage of this configuration is to isolate the ground system of the computer environment from the control field environment. Also important is the blocking of ripples and EMI signals present on each network.

For convenience the RP312 has built in Fieldbus terminator on network 1.

The RP312 can also extend the network to several kilometers if connected in a daisy chain topology. It will keep signal integrity and the original segment timing controlled by the link active scheduler, therefore messages will be sent as received, the only exception to the rule will be the loss of up to two preamble of the message. This loss will impose a maximum limit of 4 repeaters per chain. Figure 7.1.2 page 6 show connection practice for daisy chain topology.

The repeater will also support the tree topology, which can be combined with daisy chain topology as well. With tree topology the network can lead to many different directions on the plant, or to different ground-noise hazard zones, allowing the control computer to manage several areas on the same Fieldbus segment. Figure 7.1.3 page 7 show connection practices for this mixed topology.

8 Software Configuration

The RP312 will work with any Fieldbus H1 network supervisory and control system, it will require no software configuration unless the selection of the internal terminator if desirable.

9 Mechanical Dimensions

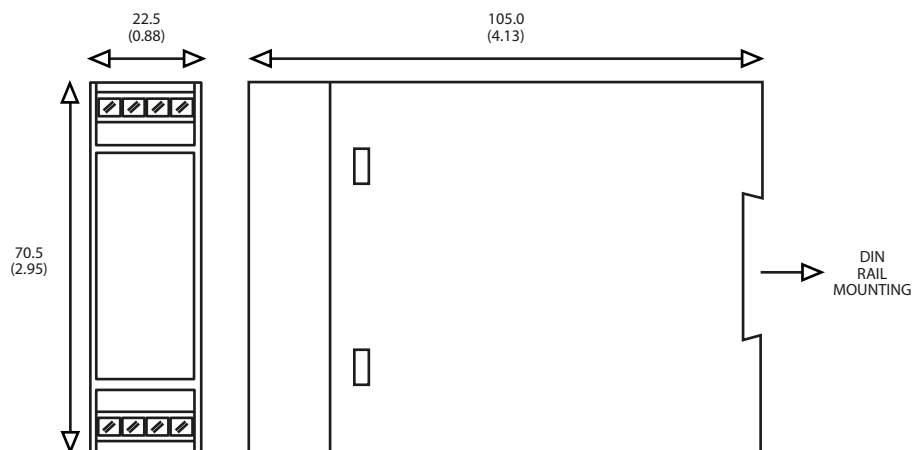

Fig. 9.1 – Mechanical Dimensions

Springfield Research reserves the right to make changes to design and functionality of any product without notice. Springfield Research does not assume any liability arising out of the application or use of any product. Springfield Research logo is registered trademarks of Springfield Research. HART is a registered trademark of the HART Communication Foundation. © 2015 Springfield Research Corp. All rights reserved



Springfield Research Corporation

3350 NW 22nd Terrace Suite 500 • Pompano Beach, FL USA 33069

Tel: +1 (954) 657.8849 • Fax: +1 (954) 657.8895 • sales@springres.com • www.springres.com

